



# SEPTRON® Line 10 – 20

Ultrapure Water Systems

## Compact Quality in the Laboratory

**Whether it is during the production process of tablets, for the manufacture of salves or creams, saps or drops, or for rinsing the packaging – water is the primary aid in the pharmaceutical industry.**

Above all in the laboratory the use of purified water in constant quality is of deciding importance for the successful repeatability of laboratory applications. For this reason regulatory authorities defined different grades of water purity according to use.

The water manufactured with the SEPTRON® Line exceeds water quality type 2 (laboratory water), as defined by ASTM, CAP, NCCLS and ISO 3696/BS 3997 and complies with both the European standards and also the requirements formulated by the American Pharmacopoeias for Purified Water.



## SEPTRON® Line – Purified Water in the Smallest Area

**SEPTRON® Technology stands for the highest water quality with the lowest conductivity as well as excellent microbiological purity. The deadleg-free water Smart Block linking technology as well as the “Full fit” concept contribute to ensuring perfect water quality. All preparation stages, from filtration to electrical demineralisation, are combined in a compact unit.**

### The advantages:

- Up to 300 l/h Purified Water in just 0.5 m<sup>2</sup>
- Ready for connection series product
- GAMP 4 conform operation with touch screen display for process visualisation
- Integrated cleaning programme
- Economical Purified Water production from 150 to 300 l/h
- Operation with 230V/50Hz
- Mobile operating panel for optional wall mounting
- Guaranteed Purified Water quality acc. to Ph.Eur & USP (VAL version)
- SEPTRON® Line VAL pre-validated with complete documentation for official proof
- Short delivery time and start-up
- User friendly and low maintenance

### Best water quality

The SEPTRON® Line versions PRO and VAL fulfil the requirements for pure water by far. The standard water quality is produced by SEPTRON® Line PRO and SEPTRON Line VAL additionally guarantees the required security for Purified Water according to Ph.Eur and USP.

### Compact and comfortable

Thanks to its small footprint SEPTRON® Line will fit in the smallest room in your laboratory. The innovative and mobile operations panel can be positioned in the workplace and in this way allows easy operation of the SEPTRON® Line from up to 5 metres away.

SEPTRON® Line PRO and VAL Typ SL 10 SL 20

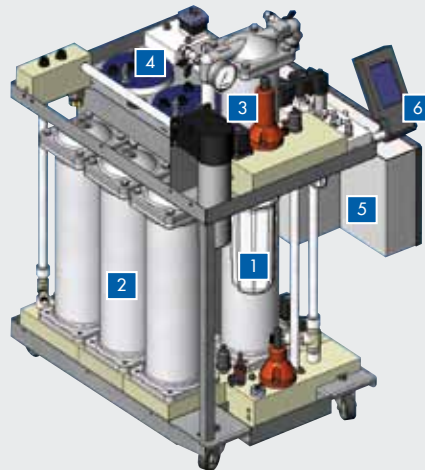
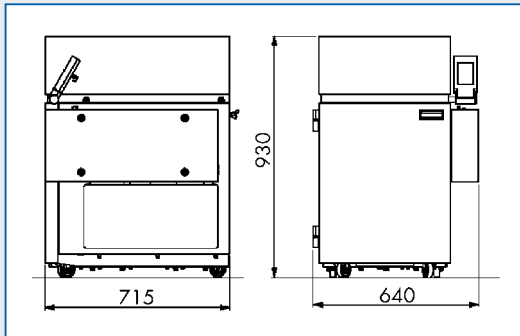

- 1 Fine filter
- 2 Reverse osmosis
- 3 High pressure pump
- 4 SEPTRON® Module
- 5 Operation
- 6 Operating panel

Clear menu guide

All operating parameters and the system status are visualised on the touch screen display in real time. The clear menu guide enables an intuitive, secure and ergonomic operation.

Easy operation

SEPTRON® Line is equipped with an innovative touch screen display for visualisation, operation and control of the individual functions.

Controlled access

SEPTRON® Line is secured by three password protected access levels in combination with an electronic key. In this way it is guaranteed that only authorised personnel can influence the production processes.

SEPTRON® Line VAL fulfils the quality requirements of the pharmaceutical industry and is compliant with GMP with regard to the necessary FDA and PIC guidelines. Due to the prequalification FAT (Factory Acceptance Test) many points of installation and functional qualification can be tested beforehand, whereby time and money is saved during the qualification.

SEPTRON® Line PRO and VAL	Type	SL 10	SL 20
Volume flow Purified Water	l/h	150	300
Effective conductivity at 25°C	µS/cm	<0,2	<0,2
TOC	ppm	<0,05	<0,05
SiO2	ppm	<0,1	<0,1
Total bacterial count	CFU/ml	<10	<10
Electrical connection	V/Hz	230/50	230/50
Electrical consumption	kW	1.2	1.45
Width	mm	640	640
Height	mm	930	930
Depth	mm	715	715

\*Softened feed water at 15 °C/6 bar

# BWT – The Company

The Best Water Technology Group was formed in 1990 and is today Europe's leading water technology company. More than 2,800 employees in over 70 subsidiaries and associates together with thousands of service employees, plumbers, planners, architects and hygiene experts constitute the BWT water partner network. Employees in Research & Development work on new processes and materials using state-of-the-art methods to target the development of ecological and at the same time economical products. Thereby the reduction of energy consumption of products and the consequent minimisation of CO<sub>2</sub> emissions is a key issue.

When it comes to water, almost everywhere, whether at the entrance of the water pipe into a building – the Point of Entry - or at the tapping point – the Point of Use, the trend-setting products by BWT are in use and have proved their quality millions of times. For the treatment of drinking water, mineral water and ultrapure water for the pharmaceutical industry as well as in swimming pools, heating and process water, boiler and cooling water as well as for water for air-conditioning. Extensive innovations

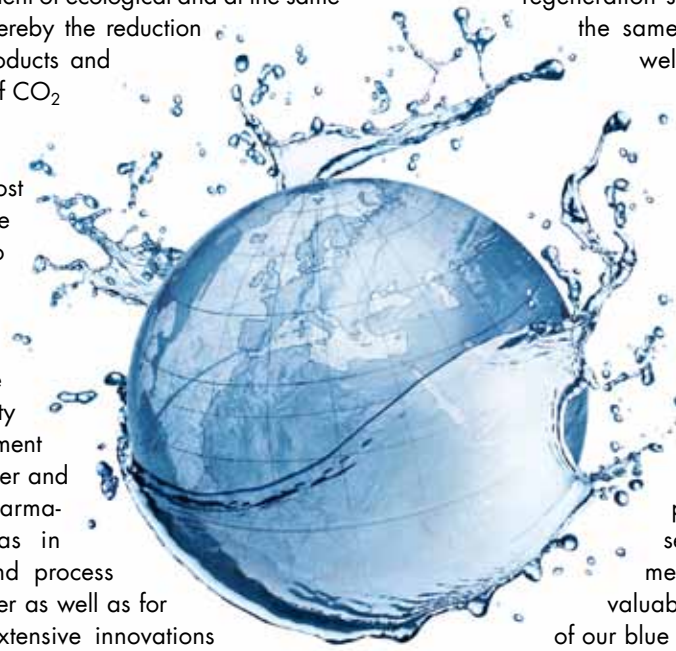

guarantee our customers maximum security, hygiene and health in the daily use of water, the precious elixir of life. These innovations, among others, include SEPTRON®, the worldwide first electrode deionisation module (EDI) with spiral wrap, the MDA (manganese oxide activation) – method for effective manganese removal, the bipolar technology AQA total for chemical-free lime protection, SANISAL – the worldwide first regeneration salt for softening systems, which at the same time works as a disinfectant as well as the new, revolutionary Mg<sup>2+</sup>-technology for better taste of filtered water, coffee and tea. With unique high efficiency membranes for fuel cells and batteries, BWT is bringing about a cleaner and sustainable energy supply in the 21<sup>st</sup> century.

BWT – For You and Planet Blue is our mission to take ecological, economical and social responsibility, to provide our customers and partners with the best products, systems, technologies and services in all areas of water treatment and simultaneously contribute valuably to preserve the global resources of our blue planet.



For You and Planet Blue.

## Contact:

### EUROPE:

**BWT Pharma & Biotech GmbH**  
Steinbeisstrasse 41 – 43, D-71665 Vaihingen  
Phone: +49/7042/910-0  
Email: [office@christaqua.com](mailto:office@christaqua.com)

### ASIA:

**BWT Water Technology (Shanghai) Co., Ltd.**  
No. 248 Xintuan Road, 12# Workshop,  
Qingpu Industry Zone, Shanghai,  
201707 Shanghai, P. R. China  
Phone: +86/21/5986-7100  
Email: [office@christaqua.com](mailto:office@christaqua.com)

